

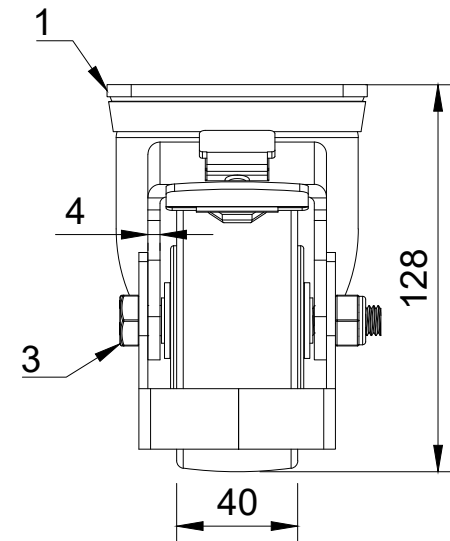

ITEM NO.	PART NUMBER	QTY
1	BZH100ASSWB	1
2	BZXH100WNYBJM15	1
3	AXLE KIT	
	TUBEM15X50/CH	1
	WP15X25X2BLK	2
	BOLTM10X80Z8.8	1
	NYLOCM10Z	1
4	FGP/100/50/10	1



UNLESS OTHERWISE SPECIFIED DIMENSIONS ARE IN MILLIMETRES  Unspecified Tolerances Machining ± 0.25mm Fabrication ± 1mm	<b>DRAWING DISCLAIMER</b>  COPYRIGHT OF THIS DRAWING IS RESERVED BY BIL GROUP LTD. IT IS NOT REPRODUCED, COPIED, OR DISCLOSED TO A THIRD PARTY EITHER WHOLLY OR IN PART WITHOUT THE CONSENT IN WRITING OF BIL GROUP LTD	<b>NAME</b> Matt	<b>DATE</b> 04/10/24	 BIL Group Ltd Porte Marsh Road Calne, Wiltshire, SN11 9BW United Kingdom Tel +44 (0)1249 822 222 www.bilgroup.co.uk	 VARLEY H Varley Ltd Unit 5 Century Park Pacific Rd, Broadheath, Altrincham, Cheshire WA14 5BJ Tel +44 (0)161 928 9617 www.varley-castors.co.uk	
		<b>DRAWN BY</b> Matt	<b>DATE</b> 04/10/24			<b>DWG NO.</b> BZH100NYBJSWBFG
		<b>APPROVED BY</b> Kevin	<b>DATE</b> 04/10/24	<b>BZH100NYBJSWBFG</b>		<b>SHEET 1 OF 1</b>
		<b>SCALE</b> 2:5	<b>WEIGHT</b> 1.57kg			