

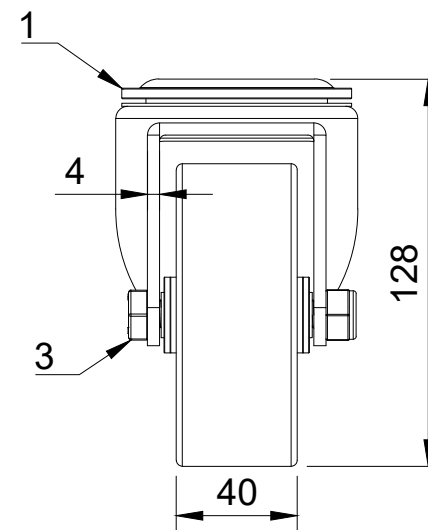

ITEM NO.	PART NUMBER	QTY
1	BZH100ASBH12	1
2	BZH100WPABJM15	1
3	AXLE KIT	
	TUBEM15X50	1
	WP15X25X2BLK	4
	HEXBOLTM10X65Z8.8	1
	NYLOCM10Z	1



UNLESS OTHERWISE SPECIFIED DIMENSIONS ARE IN MILLIMETRES Unspecified Tolerances Machining ± 0.25mm Fabrication ± 1mm	DRAWING DISCLAIMER COPYRIGHT OF THIS DRAWING IS RESERVED BY BIL GROUP LTD. IT IS NOT REPRODUCED, COPIED, OR DISCLOSED TO A THIRD PARTY EITHER WHOLLY OR IN PART WITHOUT THE CONSENT IN WRITING OF BIL GROUP LTD	NAME Matt	DATE 05/03/24		BIL Group Ltd Porte Marsh Road Calne, Wiltshire, SN11 9BW United Kingdom Tel +44 (0)1249 822 222 www.bilgroup.co.uk		
		DRAWN BY Matt	DATE 05/03/24		DWG NO. BZH100PABJBH12	REV 1	
		APPROVED BY Kevin	DATE 05/03/24	BZH100PABJBH12		SHEET 1 OF 1	
		SCALE 2:5	WEIGHT 1.132kg				