

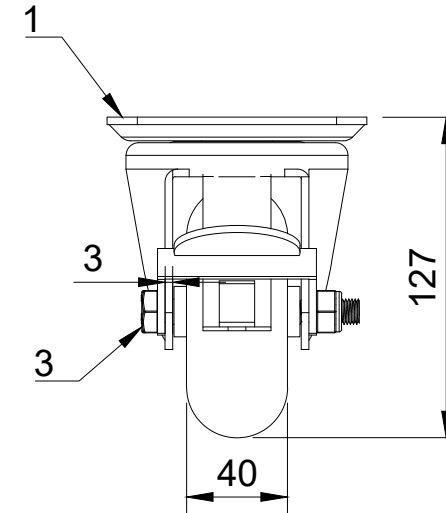

ITEM NO.	PRODUCT NUMBER	QTY
1	BZH100ASBRLP	1
2	BZH100WSRERBJM15	1
3	AXLE KIT	
	TH15X5X10	2
	BOLTM10X80Z8.8	1
	NYLOCM10Z	1



UNLESS OTHERWISE SPECIFIED DIMENSIONS ARE IN MILLIMETRES Unspecified Tolerances Machining ± 0.25mm Fabrication ± 1mm	DRAWING DISCLAIMER COPYRIGHT OF THIS DRAWING IS RESERVED BY BIL GROUP LTD. IT IS NOT REPRODUCED, COPIED, OR DISCLOSED TO A THIRD PARTY EITHER WHOLLY OR IN PART WITHOUT THE CONSENT IN WRITING OF BIL GROUP LTD	NAME Matt	DATE 22/09/23		BIL Group Ltd Porte Marsh Road Calne, Wiltshire, SN11 9BW United Kingdom Tel +44 (0)1249 822 222 www.bilgroup.co.uk	
		DRAWN BY Matt	DATE 22/09/23		DWG NO. BZH100SRERBJBRLP	REV 1
		APPROVED BY Chris	DATE 22/09/23	SCALE 1:3	BZH100SRERBJBRLP	SHEET 1 OF 1
		WEIGHT 1.325kg				