

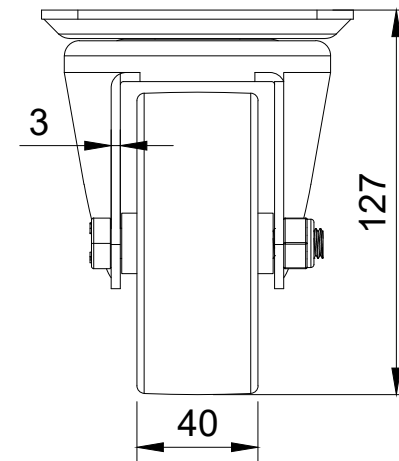

ITEM NO.	PART NUMBER	QTY
1	BZH100ASLP	1
2	BZXH100WPNBJM15	1
3	AXLE KIT	
	TH15X5X10	2
	HEXBOLTM10X70Z8.8	1
	NYLOCM10Z	1



UNLESS OTHERWISE SPECIFIED DIMENSIONS ARE IN MILLIMETRES Unspecified Tolerances Machining ± 0.25mm Fabrication ± 1mm	DRAWING DISCLAIMER COPYRIGHT OF THIS DRAWING IS RESERVED BY BIL GROUP LTD. IT IS NOT REPRODUCED, COPIED, OR DISCLOSED TO A THIRD PARTY EITHER WHOLLY OR IN PART WITHOUT THE CONSENT IN WRITING OF BIL GROUP LTD	NAME Matt	DATE 10/05/24	 BIL Group Ltd Porte Marsh Road Calne, Wiltshire, SN11 9BW United Kingdom Tel +44 (0)1249 822 222 www.bilgroup.co.uk	 H Varley Ltd Unit 5 Century Park Pacific Rd, Broadheath, Altrincham, Cheshire WA14 5BJ Tel +44 (0)161 928 9617 www.varley-castors.co.uk	
		DRAWN BY Matt	DATE 10/05/24			DWG NO. BZH100XPNBJLP
		APPROVED BY Kevin	DATE 10/05/24	BZH100XPNBJLP		SHEET 1 OF 1
		SCALE 2:5	WEIGHT 1.191kg			