

ITEM NO.	PART NUMBER	QTY
1	BZH125ASSWB	1
2	BZMH125WRPTABJM20	1
3	AXLE KIT	
	TH20X2X12	2
	TUBEM12X50X10	1
	HEXBOLTM110X70Z8.8	1
	NYLOCM10Z	1

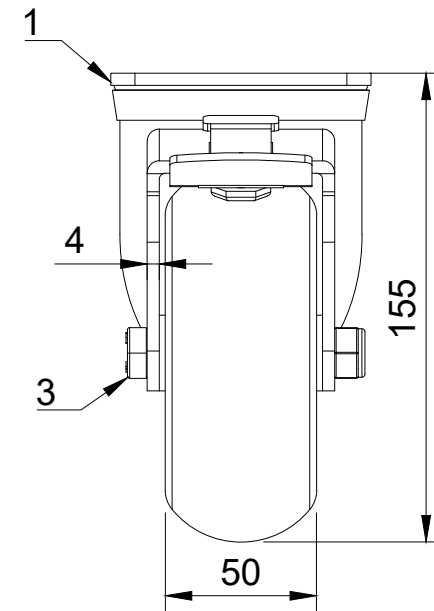

UNLESS OTHERWISE SPECIFIED DIMENSIONS ARE IN MILLIMETRES

Unspecified Tolerances
Machining ± 0.25mm
Fabrication ± 1mm

DRAWING DISCLAIMER

COPYRIGHT OF THIS DRAWING IS RESERVED BY BIL GROUP LTD. IT IS NOT REPRODUCED, COPIED, OR DISCLOSED TO A THIRD PARTY EITHER WHOLLY OR IN PART WITHOUT THE CONSENT IN WRITING OF BIL GROUP LTD

	NAME	DATE
DRAWN BY	Matt	06/09/24
APPROVED BY	Kevin	06/09/24
SCALE	2:5	
WEIGHT	2.162kg	

 <p>BIL Group Ltd Porte Marsh Road Calne, Wiltshire, SN11 9BW United Kingdom Tel +44 (0)1249 822 222 www.bilgroup.co.uk</p>	 <p>H Varley Ltd Unit 5 Century Park Pacific Rd, Broadheath, Altrincham, Cheshire WA14 5BJ Tel +44 (0)161 928 9617 www.varley-castors.co.uk</p>	DWG NO.	REV
		BZH125RPTABJSWB	1
BZH125RPTABJSWB		SHEET 1 OF 1	