

| ITEM NO. | PART NUMBER | QTY |
|----------|-------------------|-----|
| 1 | BZK250ASSWB | 1 |
| 2 | BZPMH250WPTBJM25 | 1 |
| 3 | AXLE KIT | |
| | TH25X2X12 | 2 |
| | HEXBOLTM12X90Z8.8 | 1 |
| | NYLOCM12Z | 1 |

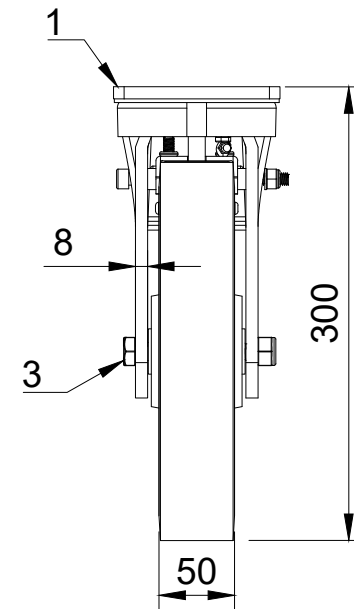

UNLESS OTHERWISE SPECIFIED DIMENSIONS ARE IN MILLIMETRES

Unspecified Tolerances
Machining ± 0.25mm
Fabrication ± 1mm

DRAWING DISCLAIMER

COPYRIGHT OF THIS DRAWING IS RESERVED BY BIL GROUP LTD. IT IS NOT REPRODUCED, COPIED, OR DISCLOSED TO A THIRD PARTY EITHER WHOLLY OR IN PART WITHOUT THE CONSENT IN WRITING OF BIL GROUP LTD

| | NAME | DATE |
|-------------|----------|----------|
| DRAWN BY | Matt | 16/01/24 |
| APPROVED BY | Kevin | 16/01/24 |
| SCALE | 1:5 | |
| WEIGHT | 10.744kg | |

BILGroup
 BIL Group Ltd
 Porte Marsh Road
 Calne, Wiltshire, SN11 9BW
 United Kingdom
 Tel +44 (0)1249 822 222
 www.bilgroup.co.uk

DWG NO. **BZK250PTBJSWB/50** REV **1**

BZK250PTBJSWB/50 SHEET 1 OF 1