

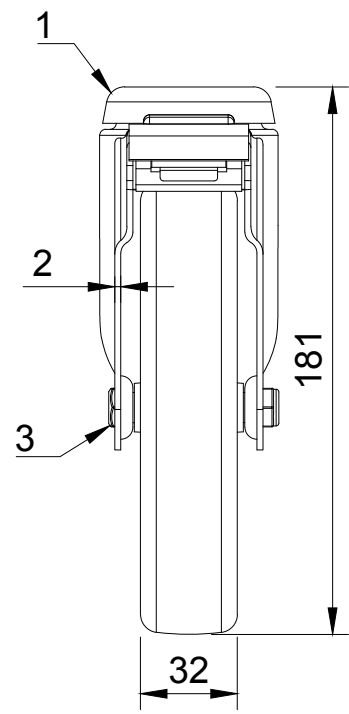

ITEM NO.	PART NUMBER	QTY
1	BZM150ASBH12SWB	1
2	BZM150WGR	1
3	AXLE KIT	
	TUBEM10X37	1
	BOLT BZM/8MM	1
	NYLOCM8Z	1



UNLESS OTHERWISE SPECIFIED DIMENSIONS ARE IN MILLIMETRES Unspecified Tolerances Machining ± 0.25mm Fabrication ± 1mm	DRAWING DISCLAIMER COPYRIGHT OF THIS DRAWING IS RESERVED BY BIL GROUP LTD. IT IS NOT REPRODUCED, COPIED, OR DISCLOSED TO A THIRD PARTY EITHER WHOLLY OR IN PART WITHOUT THE CONSENT IN WRITING OF BIL GROUP LTD	NAME Matt	DATE 21/03/25	 BIL Group Ltd Porte Marsh Road Calne, Wiltshire, SN11 9BW United Kingdom Tel +44 (0)1249 822 222 www.bilgroup.co.uk	 VARLEY H Varley Ltd Unit 5 Century Park Pacific Rd, Broadheath, Altrincham, Cheshire WA14 5BJ Tel +44 (0)161 928 9617 www.varley-castors.co.uk	
		DRAWN BY Matt	DATE 21/03/25			DWG NO. BZM150GRBH12SWB
		APPROVED BY Kevin	DATE 21/03/25			
		SCALE 2:5				
		WEIGHT 0.674kg			BZM150GRBH12SWB	SHEET 1 OF 1