

ITEM NO.	PART NUMBER	QTY
1	BZXM125ASBH12SWB	1
2	WAN125M12TF/300	1
3	AXLE KIT	
	TUBEM12X46X10	1
	HEXBOLTM10X60Z8.8	1
	NM10GR8FULLZHT	1

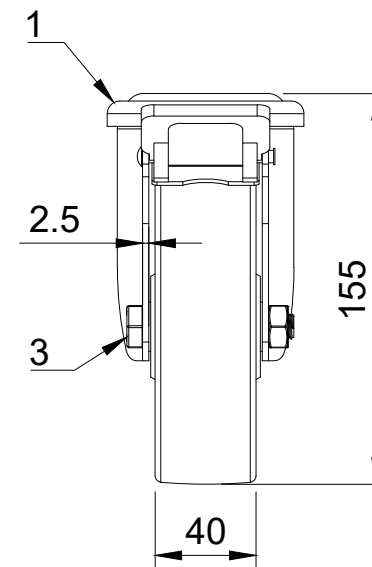

UNLESS OTHERWISE SPECIFIED DIMENSIONS ARE IN MILLIMETRES

Unspecified Tolerances
Machining ± 0.25mm
Fabrication ± 1mm

DRAWING DISCLAIMER

COPYRIGHT OF THIS DRAWING IS RESERVED BY BIL GROUP LTD. IT IS NOT REPRODUCED, COPIED, OR DISCLOSED TO A THIRD PARTY EITHER WHOLLY OR IN PART WITHOUT THE CONSENT IN WRITING OF BIL GROUP LTD

	NAME	DATE
DRAWN BY	Matt	07/12/23
APPROVED BY	Kevin	07/12/23
SCALE	1:3	
WEIGHT	1.239kg	

BILGroup

BIL Group Ltd
Porte Marsh Road
Calne, Wiltshire, SN11 9BW
United Kingdom
Tel +44 (0)1249 822 222
www.bilgroup.co.uk

DWG NO. **BZMH125AN3BH12TFSWB** REV **1**

BZMH125AN3BH12TFSWB SHEET 1 OF 1