

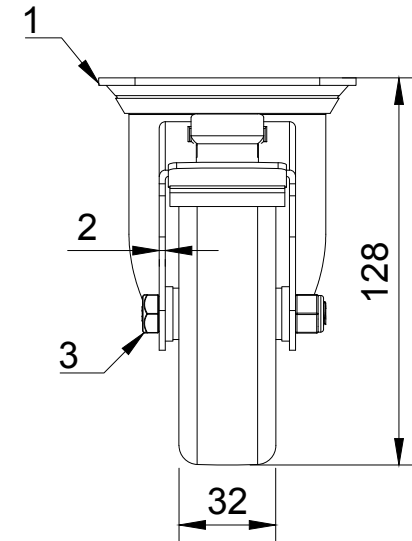

| ITEM NO. | PART NUMBER | QTY |
|----------|------------------|-----|
| 1 | BZMM100ASSWB | 1 |
| 2 | BZM100WGREC | 1 |
| 3 | AXLE KIT | |
| | TUBEM12X40 | 1 |
| | WP12X18X2.5BLK | 2 |
| | HEXBOLTM8X55Z8.8 | 1 |
| | NYLOCM8Z | 1 |



| | | | | | |
|---|---|-----------------------------|-------------------------|---|---|
| UNLESS OTHERWISE SPECIFIED DIMENSIONS ARE IN MILLIMETRES Unspecified Tolerances Machining ± 0.25mm Fabrication ± 1mm | DRAWING DISCLAIMER COPYRIGHT OF THIS DRAWING IS RESERVED BY BIL GROUP LTD. IT IS NOT REPRODUCED, COPIED, OR DISCLOSED TO A THIRD PARTY EITHER WHOLLY OR IN PART WITHOUT THE CONSENT IN WRITING OF BIL GROUP LTD | NAME Matt | DATE 21/01/25 |  BIL Group Ltd Porte Marsh Road Calne, Wiltshire, SN11 9BW United Kingdom Tel +44 (0)1249 822 222 www.bilgroup.co.uk |  VARLEY H Varley Ltd Unit 5 Century Park Pacific Rd, Broadheath, Altrincham, Cheshire WA14 5BJ Tel +44 (0)161 928 9617 www.varley-castors.co.uk |
| | | DRAWN BY Matt | DATE 21/01/25 | | |
| | | APPROVED BY Kevin | DATE 21/01/25 | BZMM100GRECSWB | |
| | | SCALE 2:5 | | BZMM100GRECSWB | |
| | | WEIGHT 0.704kg | | SHEET 1 OF 1 | |