

ITEM NO.	PART NUMBER	QTY
1	BZMM100ASBH12SWB	1
2	BZH100WNPBJ	1
	BEARING6201	2
3	AXLE KIT	
	TUBEM12X40	1
	HEXBOLTM8X55Z8.8	1
	NYLOCM8Z	1

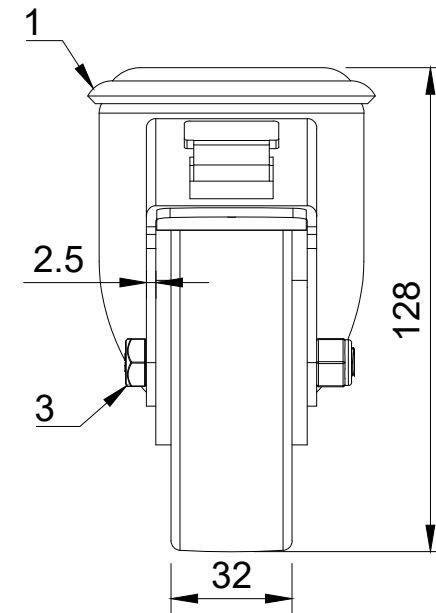

UNLESS OTHERWISE SPECIFIED DIMENSIONS ARE IN MILLIMETRES

Unspecified Tolerances
Machining ± 0.25mm
Fabrication ± 1mm

DRAWING DISCLAIMER

COPYRIGHT OF THIS DRAWING IS RESERVED BY BIL GROUP LTD. IT IS NOT REPRODUCED, COPIED, OR DISCLOSED TO A THIRD PARTY EITHER WHOLLY OR IN PART WITHOUT THE CONSENT IN WRITING OF BIL GROUP LTD

	NAME	DATE
DRAWN BY	Matt	15/11/24
APPROVED BY	Kevin	15/11/24
SCALE	1:2	
WEIGHT	0.911kg	

BIL Group Ltd
Porte Marsh Road
Calne, Wiltshire,
SN11 9BW
United Kingdom
Tel +44 (0)1249 822 222
www.bilgroup.co.uk

H Varley Ltd
Unit 5 Century Park
Pacific Rd, Broadheath,
Altrincham, Cheshire
WA14 5BJ
Tel +44 (0)161 928 9617
www.varley-castors.co.uk

DWG NO.	REV
BZMM100NPBJBH12SWB	1
BZMM100NPBJBH12SWB SHEET 1 OF 1	