

ITEM NO.	PART NUMBER	QTY
1	BZMM100ASBH12	1
2	BZML100WPLRB	1
3	AXLE KIT	
	TUBEM12X40	1
	HEXBOLTM8X55Z8.8	1
	NYLOCM8Z	1

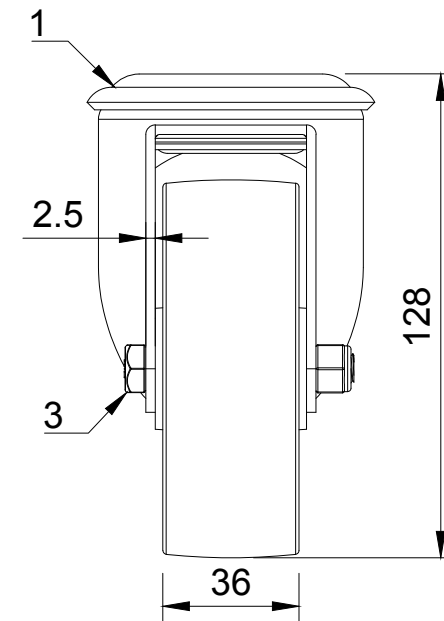

UNLESS OTHERWISE SPECIFIED DIMENSIONS ARE IN MILLIMETRES

Unspecified Tolerances  
Machining ± 0.25mm  
Fabrication ± 1mm

DRAWING DISCLAIMER

COPYRIGHT OF THIS DRAWING IS RESERVED BY BIL GROUP LTD. IT IS NOT REPRODUCED, COPIED, OR DISCLOSED TO A THIRD PARTY EITHER WHOLLY OR IN PART WITHOUT THE CONSENT IN WRITING OF BIL GROUP LTD

	NAME	DATE
DRAWN BY	Matt	11/12/24
APPROVED BY	Kevin	16/12/24
SCALE	1:2	
WEIGHT	0.65kg	

BIL Group Ltd  
Porte Marsh Road  
Calne, Wiltshire,  
SN11 9BW  
United Kingdom  
Tel +44 (0)1249 822 222  
www.bilgroup.co.uk

H Varley Ltd  
Unit 5 Century Park  
Pacific Rd, Broadheath,  
Atrincham, Cheshire  
WA14 5BJ  
Tel +44 (0)161 928 9617  
www.varley-castors.co.uk

DWG NO.	BZMM100PLBBH12	REV 1
BZMM100PLBBH12		SHEET 1 OF 1