

ITEM NO.	PART NUMBER	QTY
1	BZMM100ASBH12SWB	1
2	BZH100WSRERBJM15	1
3	AXLE KIT	
	TUBEM15X40X10	1
	NYLONBUSH	1
	HEXBOLTM8X55Z8.8	1
	NYLOCM8Z	1

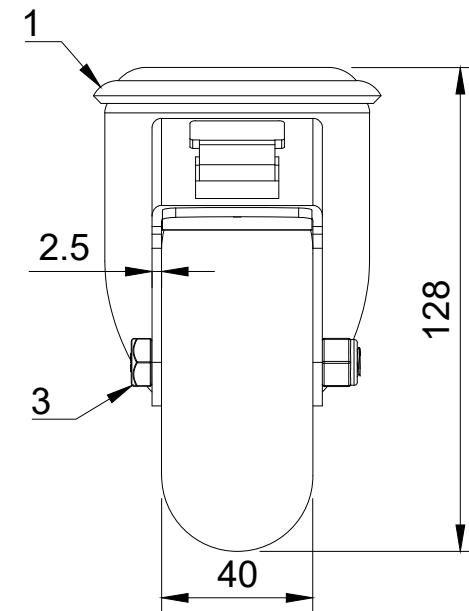

UNLESS OTHERWISE SPECIFIED DIMENSIONS ARE IN MILLIMETRES

Unspecified Tolerances  
Machining ± 0.25mm  
Fabrication ± 1mm

DRAWING DISCLAIMER

COPYRIGHT OF THIS DRAWING IS RESERVED BY BIL GROUP LTD. IT IS NOT REPRODUCED, COPIED, OR DISCLOSED TO A THIRD PARTY EITHER WHOLLY OR IN PART WITHOUT THE CONSENT IN WRITING OF BIL GROUP LTD

	NAME	DATE
DRAWN BY	Matt	11/11/24
APPROVED BY	Kevin	11/11/24
SCALE	1:2	
WEIGHT	1.063kg	

BIL Group Ltd  
Porte Marsh Road  
Calne, Wiltshire,  
SN11 9BW  
United Kingdom  
Tel +44 (0)1249 822 222  
www.bilgroup.co.uk

**BILGroup**

H Varley Ltd  
Unit 5 Century Park  
Pacific Rd, Broadheath,  
Altrincham, Cheshire  
WA14 5BJ  
Tel +44 (0)161 928 9617  
www.varley-castors.co.uk

**VARLEY**

DWG NO.	REV
BZMM100SRERBJBH12SWB	1
BZMM100SRERBJBH12SWB SHEET 1 OF 1	