

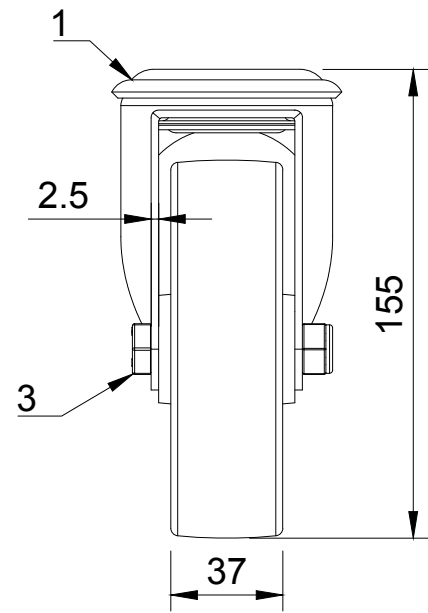

ITEM NO.	PART NUMBER	QTY
1	BZMM125ASBH12	1
2	BZMH125WPLRB	1
3	AXLE KIT	
	TUBEM15X45/CH	1
	HEXBOLTM10X60Z8.8	1
	NYLOCM10Z	1



UNLESS OTHERWISE SPECIFIED DIMENSIONS ARE IN MILLIMETRES Unspecified Tolerances Machining ± 0.25mm Fabrication ± 1mm	DRAWING DISCLAIMER COPYRIGHT OF THIS DRAWING IS RESERVED BY BIL GROUP LTD. IT IS NOT REPRODUCED, COPIED, OR DISCLOSED TO A THIRD PARTY EITHER WHOLLY OR IN PART WITHOUT THE CONSENT IN WRITING OF BIL GROUP LTD	DRAWN BY Matt	NAME Matt	DATE 03/01/25	 BIL Group Ltd Porte Marsh Road Calne, Wiltshire, SN11 9BW United Kingdom Tel +44 (0)1249 822 222 www.bilgroup.co.uk	 VARLEY H Varley Ltd Unit 5 Century Park Pacific Rd, Broadheath, Altrincham, Cheshire WA14 5BJ Tel +44 (0)161 928 9617 www.varley-castors.co.uk
		APPROVED BY Kevin	NAME Kevin	DATE 03/01/25		
		SCALE 2:5	WEIGHT 0.778kg	DWG NO. BZMM125PLBBH12		REV 1
				DWG NO. BZMM125PLBBH12		REV 1
				DWG NO. BZMM125PLBBH12		REV 1