

ITEM NO.	PART NUMBER	QTY
1	BZMM125ASBH12SWB	1
2	BZMH125WSRNBJM10	1
3	AXLE KIT	
	HEXBOLTM10X60Z8.8	1
	NYLOCM10Z	1

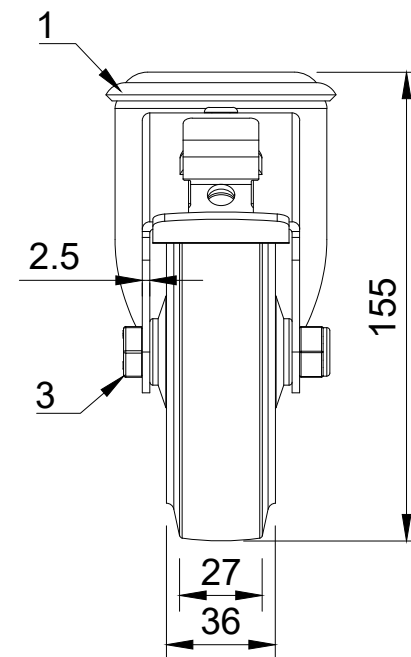

UNLESS OTHERWISE SPECIFIED DIMENSIONS ARE IN MILLIMETRES

Unspecified Tolerances
Machining ± 0.25mm
Fabrication ± 1mm

DRAWING DISCLAIMER

COPYRIGHT OF THIS DRAWING IS RESERVED BY BIL GROUP LTD. IT IS NOT REPRODUCED, COPIED, OR DISCLOSED TO A THIRD PARTY EITHER WHOLLY OR IN PART WITHOUT THE CONSENT IN WRITING OF BIL GROUP LTD

	NAME	DATE
DRAWN BY	Matt	15/10/24
APPROVED BY	Kevin	15/10/24
SCALE	2:5	
WEIGHT	1.093kg	

 BIL Group Ltd Porte Marsh Road Calne, Wiltshire, SN11 9BW United Kingdom Tel +44 (0)1249 822 222 www.bilgroup.co.uk	 VARLEY H Varley Ltd Unit 5 Century Park Pacific Rd, Broadheath, Altrincham, Cheshire WA14 5BJ Tel +44 (0)161 928 9617 www.varley-castors.co.uk	DWG NO.	REV
		BZMM125SRNBJBH12SWB	1
BZMM125SRNBJBH12SWB		SHEET 1 OF 1	