

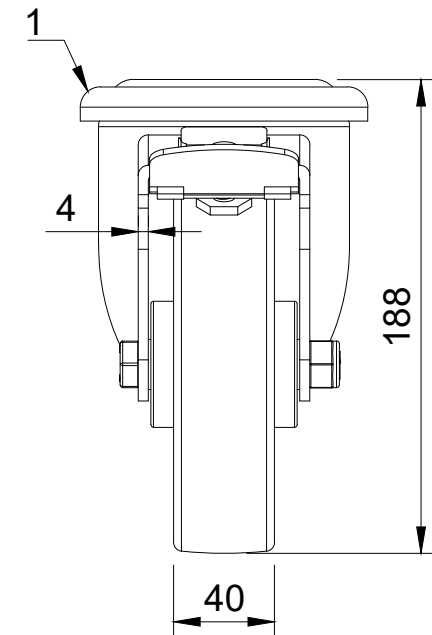

| ITEM NO. | PART NUMBER | QTY |
|----------|-------------------|-----|
| 1 | BZMM150ASBH16SWB | 1 |
| 2 | BZH150WNPRB | 1 |
| 3 | AXLE KIT | |
| | TUBEM20X60/CH | 1 |
| | HEXBOLTM12X80Z8.8 | 1 |
| | NYLOCM12Z | 1 |



| | | | | | |
|---|---|-------------------------------------|-------------------------|---|---|
| UNLESS OTHERWISE SPECIFIED DIMENSIONS ARE IN MILLIMETRES Unspecified Tolerances Machining ± 0.25mm Fabrication ± 1mm | DRAWING DISCLAIMER COPYRIGHT OF THIS DRAWING IS RESERVED BY BIL GROUP LTD. IT IS NOT REPRODUCED, COPIED, OR DISCLOSED TO A THIRD PARTY EITHER WHOLLY OR IN PART WITHOUT THE CONSENT IN WRITING OF BIL GROUP LTD | NAME Matt | DATE 18/11/24 |  BIL Group Ltd Porte Marsh Road Calne, Wiltshire, SN11 9BW United Kingdom Tel +44 (0)1249 822 222 www.bilgroup.co.uk |  H Varley Ltd Unit 5 Century Park Pacific Rd, Broadheath, Altrincham, Cheshire WA14 5BJ Tel +44 (0)161 928 9617 www.varley-castors.co.uk |
| | | DRAWN BY Matt | 18/11/24 | | |
| | | APPROVED BY Kevin | 18/11/24 | | |
| | | SCALE 1:3 | | | |
| | | WEIGHT 2.573kg | | | |
| | | DWG NO. BZMM150NPBBH16SWB | | REV 1 | |
| | | BZMM150NPBBH16SWB | | SHEET 1 OF 1 | |