

| ITEM NO. | PART NUMBER       | QTY |
|----------|-------------------|-----|
| 1        | BZMM150ASBH16SWB  | 1   |
| 2        | BZH150WNP         | 1   |
| 3        | AXLE KIT          |     |
|          | TUBEM20X60        | 1   |
|          | HEXBOLTM12X80Z8.8 | 1   |
|          | NYLOCM12Z         | 1   |

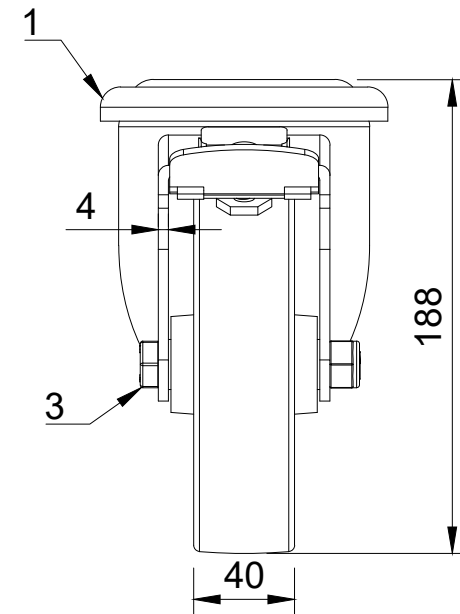

UNLESS OTHERWISE SPECIFIED DIMENSIONS ARE IN MILLIMETRES

Unspecified Tolerances  
Machining ± 0.25mm  
Fabrication ± 1mm

DRAWING DISCLAIMER

COPYRIGHT OF THIS DRAWING IS RESERVED BY BIL GROUP LTD. IT IS NOT REPRODUCED, COPIED, OR DISCLOSED TO A THIRD PARTY EITHER WHOLLY OR IN PART WITHOUT THE CONSENT IN WRITING OF BIL GROUP LTD

|             | NAME    | DATE     |
|-------------|---------|----------|
| DRAWN BY    | Matt    | 18/11/24 |
| APPROVED BY | Kevin   | 18/11/24 |
| SCALE       | 1:3     |          |
| WEIGHT      | 2.491kg |          |

|  |  |                  |     |
|--|--|------------------|-----|
|  <p>BIL Group Ltd<br/>Porte Marsh Road<br/>Calne, Wiltshire,<br/>SN11 9BW<br/>United Kingdom<br/>Tel +44 (0)1249 822 222<br/>www.bilgroup.co.uk</p> |  <p>H Varley Ltd<br/>Unit 5 Century Park<br/>Pacific Rd, Broadheath,<br/>Altrincham, Cheshire<br/>WA14 5BJ<br/>Tel +44 (0)161 928 9617<br/>www.varley-castors.co.uk</p> | DWG NO.          | REV |
|  |  | BZMM150NPBH16SWB | 1   |
| BZMM150NPBH16SWB   |  | SHEET 1 OF 1     |     |