

| ITEM NO. | PART NUMBER | QTY |
|----------|-------------------|-----|
| 1 | BZMM150ASBH12SWB | 1 |
| 2 | BZMM150WNYBJM2060 | 1 |
| 3 | AXLE KIT | |
| | TH20X2X12 | 2 |
| | HEXBOLTM12X80Z8.8 | 1 |
| | NYLOCM12Z | 1 |

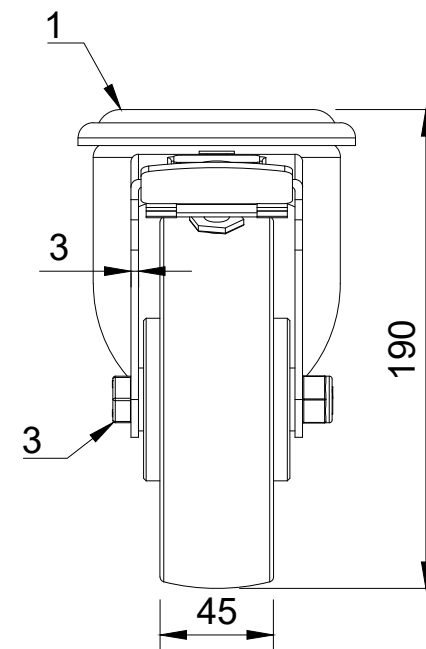

UNLESS OTHERWISE SPECIFIED DIMENSIONS ARE IN MILLIMETRES

Unspecified Tolerances
Machining ± 0.25mm
Fabrication ± 1mm

DRAWING DISCLAIMER

COPYRIGHT OF THIS DRAWING IS RESERVED BY BIL GROUP LTD. IT IS NOT REPRODUCED, COPIED, OR DISCLOSED TO A THIRD PARTY EITHER WHOLLY OR IN PART WITHOUT THE CONSENT IN WRITING OF BIL GROUP LTD

| | NAME | DATE |
|-------------|---------|----------|
| DRAWN BY | Matt | 13/09/24 |
| APPROVED BY | Kevin | 13/09/24 |
| SCALE | 1:3 | |
| WEIGHT | 2.414kg | |

| | | | |
|--|--|--------------------|-----|
|  <p>BIL Group Ltd Porte Marsh Road Calne, Wiltshire, SN11 9BW United Kingdom Tel +44 (0)1249 822 222 www.bilgroup.co.uk</p> |  <p>H Varley Ltd Unit 5 Century Park Pacific Rd, Broadheath, Altrincham, Cheshire WA14 5BJ Tel +44 (0)161 928 9617 www.varley-castors.co.uk</p> | DWG NO. | REV |
| | | BZMM150NYBJBH12SWB | 1 |
| BZMM150NYBJBH12SWB | | SHEET 1 OF 1 | |