

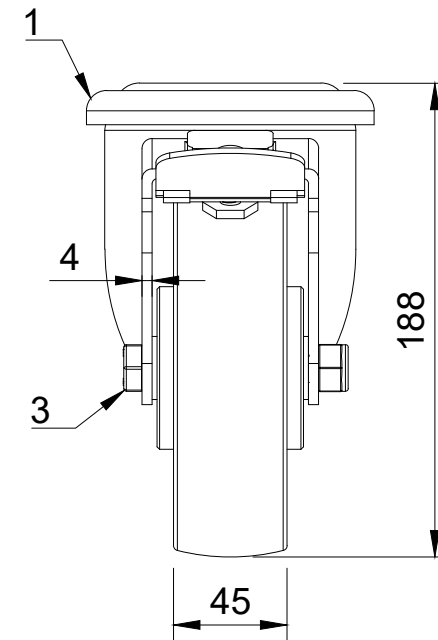

ITEM NO.	PART NUMBER	QTY
1	BZMM150ASBH16SWB	1
2	BZH150WNYBJM20/60	1
3	AXLE KIT	
	TH20X2X12	2
	HEXBOLTM12X80Z8.8	1
	NYLOCM12Z	1



<p>UNLESS OTHERWISE SPECIFIED DIMENSIONS ARE IN MILLIMETRES</p> <p>Unspecified Tolerances Machining ± 0.25mm Fabrication ± 1mm</p>	<p>DRAWING DISCLAIMER</p> <p>COPYRIGHT OF THIS DRAWING IS RESERVED BY BIL GROUP LTD. IT IS NOT REPRODUCED, COPIED, OR DISCLOSED TO A THIRD PARTY EITHER WHOLLY OR IN PART WITHOUT THE CONSENT IN WRITING OF BIL GROUP LTD</p>	NAME	DATE	 <p>BIL Group Ltd Porte Marsh Road Calne, Wiltshire, SN11 9BW United Kingdom Tel +44 (0)1249 822 222 www.bilgroup.co.uk</p>	 <p>H Varley Ltd Unit 5 Century Park Pacific Rd, Broadheath, Altrincham, Cheshire WA14 5BJ Tel +44 (0)161 928 9617 www.varley-castors.co.uk</p>	
		DRAWN BY	Matt			16/09/24
		APPROVED BY	Kevin			16/09/24
		SCALE	1:3			
		WEIGHT	2.692kg			
<p>DWG NO. BZMM150NYBJBH16SWB</p>			REV	1		
<p>BZMM150NYBJBH16SWB</p>			<p>SHEET 1 OF 1</p>			