

ITEM NO.	PART NUMBER	QTY
1	BZMM150ASSWB	1
2	BZH150WSRERGBJM20	1
3	AXLE KIT	
	TH20X5X12	2
	HEXBOLTM12X80Z8.8	1
	NYLOCM12Z	1

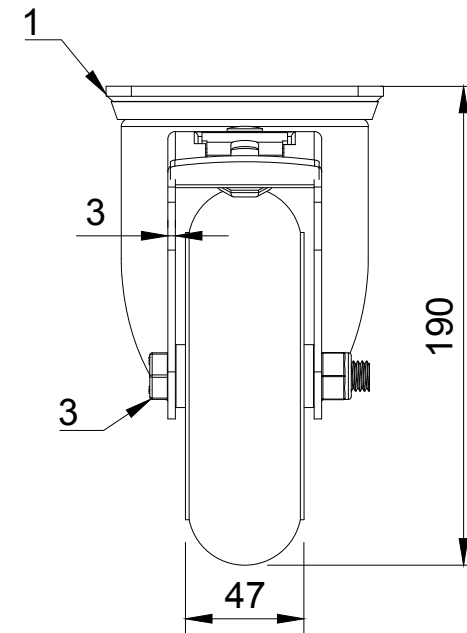

UNLESS OTHERWISE SPECIFIED DIMENSIONS ARE IN MILLIMETRES

Unspecified Tolerances
Machining ± 0.25mm
Fabrication ± 1mm

DRAWING DISCLAIMER

COPYRIGHT OF THIS DRAWING IS RESERVED BY BIL GROUP LTD. IT IS NOT REPRODUCED, COPIED, OR DISCLOSED TO A THIRD PARTY EITHER WHOLLY OR IN PART WITHOUT THE CONSENT IN WRITING OF BIL GROUP LTD

	NAME	DATE
DRAWN BY	Matt	08/01/25
APPROVED BY	Kevin	08/01/25
SCALE	1:3	
WEIGHT	2.624kg	

 BIL Group Ltd Porte Marsh Road Calne, Wiltshire, SN11 9BW United Kingdom Tel +44 (0)1249 822 222 www.bilgroup.co.uk	 VARLEY H Varley Ltd Unit 5 Century Park Pacific Rd, Broadheath, Altrincham, Cheshire WA14 5BJ Tel +44 (0)161 928 9617 www.varley-castors.co.uk	DWG NO.	REV
		BZMM150SRERGBJSWB	1
BZMM150SRERGBJSWB		SHEET 1 OF 1	