

ITEM NO.	PART NUMBER	QTY
1	BZMM150AS	1
2	BZH160WSRERGBJM20	1
3	AXLE KIT	
	TH20X2X12	2
	HEXBOLTM12X90Z8.8	1
	NYLOCM12Z	1

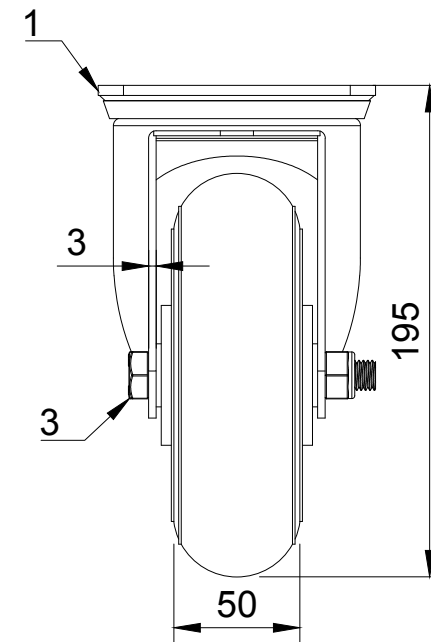

UNLESS OTHERWISE SPECIFIED DIMENSIONS ARE IN MILLIMETRES

Unspecified Tolerances
Machining ± 0.25mm
Fabrication ± 1mm

DRAWING DISCLAIMER

COPYRIGHT OF THIS DRAWING IS RESERVED BY BIL GROUP LTD. IT IS NOT REPRODUCED, COPIED, OR DISCLOSED TO A THIRD PARTY EITHER WHOLLY OR IN PART WITHOUT THE CONSENT IN WRITING OF BIL GROUP LTD

	NAME	DATE
DRAWN BY	Matt	17/12/24
APPROVED BY	Kevin	17/12/24
SCALE	1:3	
WEIGHT	2.451kg	

BIL Group Ltd
Porte Marsh Road
Calne, Wiltshire,
SN11 9BW
United Kingdom
Tel +44 (0)1249 822 222
www.bilgroup.co.uk

H Varley Ltd
Unit 5 Century Park
Pacific Rd, Broadheath,
Altrincham, Cheshire
WA14 5BJ
Tel +44 (0)161 928 9617
www.varley-castors.co.uk

DWG NO.	BZMM160SRERGBJ	REV 1
BZMM160SRERGBJ		SHEET 1 OF 1