

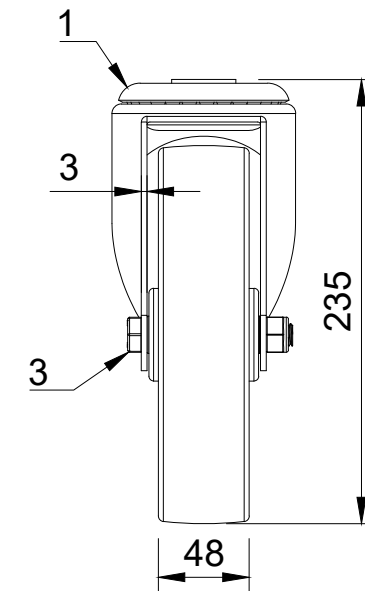

ITEM NO.	PART NUMBER	QTY
1	BZMM200ASBH12	1
2	BZMM200WNPRB20/58	1
3	AXLE KIT	
	TUBEM20X58/60	1
	HEXBOLTM12X80Z8.8	1
	NYLOCM12Z	1



<p>UNLESS OTHERWISE SPECIFIED DIMENSIONS ARE IN MILLIMETRES</p> <p>Unspecified Tolerances Machining ± 0.25mm Fabrication ± 1mm</p>	<p>DRAWING DISCLAIMER</p> <p>COPYRIGHT OF THIS DRAWING IS RESERVED BY BIL GROUP LTD. IT IS NOT REPRODUCED, COPIED, OR DISCLOSED TO A THIRD PARTY EITHER WHOLLY OR IN PART WITHOUT THE CONSENT IN WRITING OF BIL GROUP LTD</p>	NAME	DATE	 <p>BIL Group Ltd Porte Marsh Road Calne, Wiltshire, SN11 9BW United Kingdom Tel +44 (0)1249 822 222 www.bilgroup.co.uk</p>	 <p>H Varley Ltd Unit 5 Century Park Pacific Rd, Broadheath, Altrincham, Cheshire WA14 5BJ Tel +44 (0)161 928 9617 www.varley-castors.co.uk</p>	
		DRAWN BY	Matt			20/11/24
		APPROVED BY	Kevin	21/11/24	DWG NO.	REV
		SCALE	1:4		BZMM200NPBBH12	1
		WEIGHT	2.281kg		BZMM200NPBBH12	SHEET 1 OF 1