

| ITEM NO. | PART NUMBER | QTY |
|----------|------------------|-----|
| 1 | BZMMF100AS | 1 |
| 2 | WANL100M12/300 | 1 |
| 3 | AXLE KIT | |
| | TUBEM12X40SS | 1 |
| | HEXBOLTM8X55Z8.8 | 1 |
| | NM8GR8FULLZ/HT | 1 |

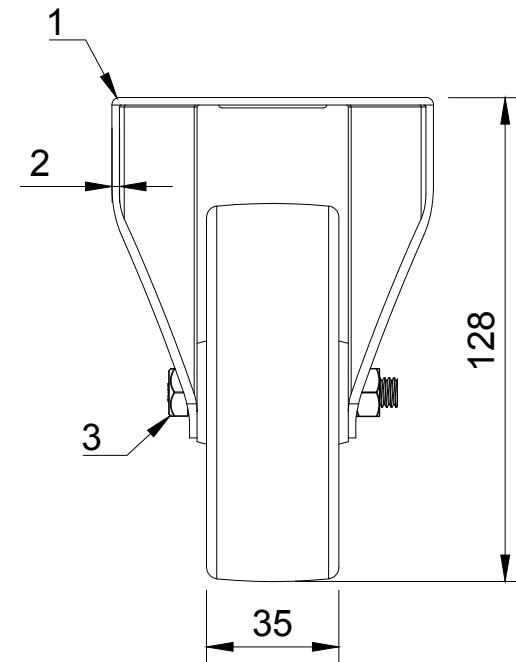

UNLESS OTHERWISE SPECIFIED DIMENSIONS ARE IN MILLIMETRES

Unspecified Tolerances
Machining ± 0.25mm
Fabrication ± 1mm

DRAWING DISCLAIMER

COPYRIGHT OF THIS DRAWING IS RESERVED BY BIL GROUP LTD. IT IS NOT REPRODUCED, COPIED, OR DISCLOSED TO A THIRD PARTY EITHER WHOLLY OR IN PART WITHOUT THE CONSENT IN WRITING OF BIL GROUP LTD

| | NAME | DATE |
|-------------|---------|----------|
| DRAWN BY | Matt | 07/01/25 |
| APPROVED BY | Kevin | 07/01/25 |
| SCALE | 1:2 | |
| WEIGHT | 0.547kg | |

| | | | |
|---|---|--------------|-----|
|  BIL Group Ltd Porte Marsh Road Calne, Wiltshire, SN11 9BW United Kingdom Tel +44 (0)1249 822 222 www.bilgroup.co.uk |  VARLEY H Varley Ltd Unit 5 Century Park Pacific Rd, Broadheath, Altrincham, Cheshire WA14 5BJ Tel +44 (0)161 928 9617 www.varley-castors.co.uk | DWG NO. | REV |
| | | BZMMF100LAN3 | 1 |
| BZMMF100LAN3 | | SHEET 1 OF 1 | |