

ITEM NO.	PART NUMBER	QTY
1	BZMMF150AS	1
2	BZH150WSRERBJM20	1
3	AXLE KIT	
	TH20X5X12	2
	HEXBOLTM12X80Z8.8	1
	NYLOCM12Z	1

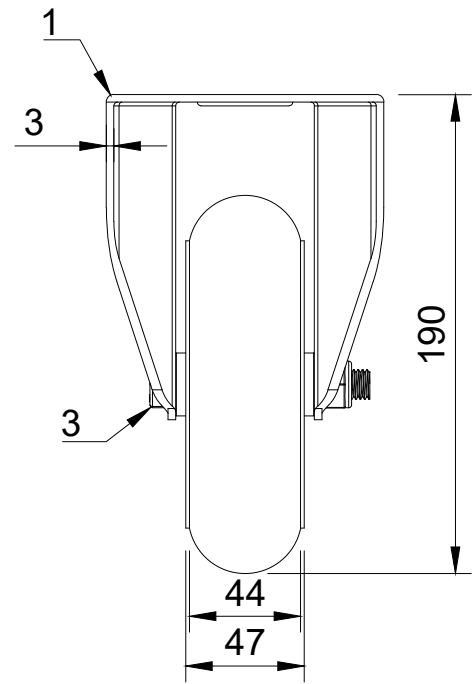

UNLESS OTHERWISE SPECIFIED DIMENSIONS ARE IN MILLIMETRES  Unspecified Tolerances Machining ± 0.25mm Fabrication ± 1mm	<b>DRAWING DISCLAIMER</b>  COPYRIGHT OF THIS DRAWING IS RESERVED BY BIL GROUP LTD. IT IS NOT REPRODUCED, COPIED, OR DISCLOSED TO A THIRD PARTY EITHER WHOLLY OR IN PART WITHOUT THE CONSENT IN WRITING OF BIL GROUP LTD	<b>NAME</b> Matt	<b>DATE</b> 27/08/24	BIL Group Ltd Porte Marsh Road Calne, Wiltshire, SN11 9BW United Kingdom Tel +44 (0)1249 822 222 www.bilgroup.co.uk	H Varley Ltd Unit 5 Century Park Pacific Rd, Broadheath, Altrincham, Cheshire WA14 5BJ Tel +44 (0)161 928 9617 www.varley-castors.co.uk
		<b>DRAWN BY</b> Matt	<b>DATE</b> 27/08/24		
		<b>APPROVED BY</b> Kevin	<b>DATE</b> 27/08/24	<b>BZMMF150SRERBJ</b>	
		<b>SCALE</b> 1:3	<b>WEIGHT</b> 1.882kg	SHEET 1 OF 1	