

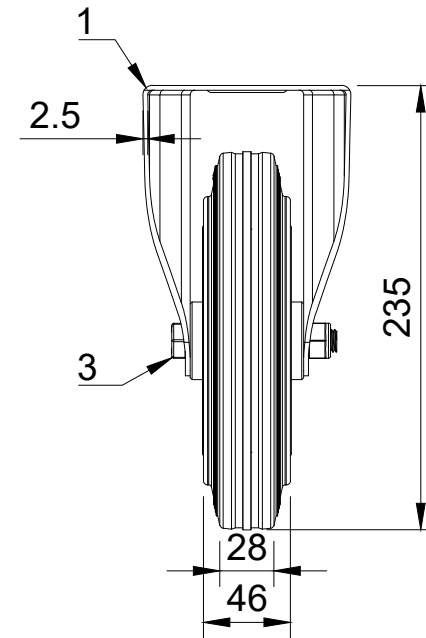

| ITEM NO. | PART NUMBER | QTY |
|----------|-------------------|-----|
| 1 | BZMMF200AS/LITE | 1 |
| 2 | BZH200WGRRB | 1 |
| 3 | AXLE KIT | |
| | TUBEM20X60/CH | 1 |
| | HEXBOLTM12X80Z8.8 | 1 |
| | NYLOCM12Z | 1 |



| | | | | | |
|---|---|-----------------------------|-------------------------|---|--|
| UNLESS OTHERWISE SPECIFIED DIMENSIONS ARE IN MILLIMETRES Unspecified Tolerances Machining ± 0.25mm Fabrication ± 1mm | DRAWING DISCLAIMER COPYRIGHT OF THIS DRAWING IS RESERVED BY BIL GROUP LTD. IT IS NOT REPRODUCED, COPIED, OR DISCLOSED TO A THIRD PARTY EITHER WHOLLY OR IN PART WITHOUT THE CONSENT IN WRITING OF BIL GROUP LTD | NAME Matt | DATE 27/06/24 |  BIL Group Ltd Porte Marsh Road Calne, Wiltshire, SN11 9BW United Kingdom Tel +44 (0)1249 822 222 www.bilgroup.co.uk |  VARLEY H Varley Ltd Unit 5 Century Park Pacific Rd, Broadheath, Altrincham, Cheshire WA14 5BJ Tel +44 (0)161 928 9617 www.varley-castors.co.uk |
| | | DRAWN BY Matt | DATE 27/06/24 | | |
| | | APPROVED BY Chris | DATE 27/06/24 | DWG NO. BZMMF200GRB | REV 1 |
| | | SCALE 1:4 | | BZMMF200GRB | |
| | | WEIGHT 2.323kg | | BZMMF200GRB | SHEET 1 OF 1 |