

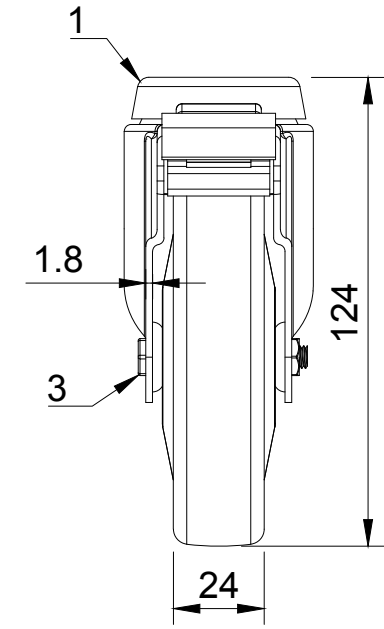

ITEM NO.	PART NUMBER	QTY
1	BZRA100ASBH10SWB	1
2	BZL100WREC	1
3	AXLE KIT	
	TG71/6	2
	TUBEM8X30	1
	BOLTBZRA/6MM	1
	NM6GR8HALFGR8	1



<p>UNLESS OTHERWISE SPECIFIED DIMENSIONS ARE IN MILLIMETRES</p> <p>Unspecified Tolerances Machining ± 0.25mm Fabrication ± 1mm</p>	<p>DRAWING DISCLAIMER</p> <p>COPYRIGHT OF THIS DRAWING IS RESERVED BY BIL GROUP LTD. IT IS NOT REPRODUCED, COPIED, OR DISCLOSED TO A THIRD PARTY EITHER WHOLLY OR IN PART WITHOUT THE CONSENT IN WRITING OF BIL GROUP LTD</p>	NAME	DATE	 <p>BIL Group Ltd Porte Marsh Road Calne, Wiltshire, SN11 9BW United Kingdom Tel +44 (0)1249 822 222 www.bilgroup.co.uk</p>  <p>H Varley Ltd Unit 5 Century Park Pacific Rd, Broadheath, Altrincham, Cheshire WA14 5BJ Tel +44 (0)161 928 9617 www.varley-castors.co.uk</p>	
		DRAWN BY	Matt		11/03/25
		APPROVED BY	Kevin		14/03/25
		SCALE	1:2		
		WEIGHT	0.401kg		
<p>DWG NO. BZRA100GRECBH10SWBG</p>		REV	1		
<p>BZRA100GRECBH10SWBG</p>		<p>SHEET 1 OF 1</p>			