

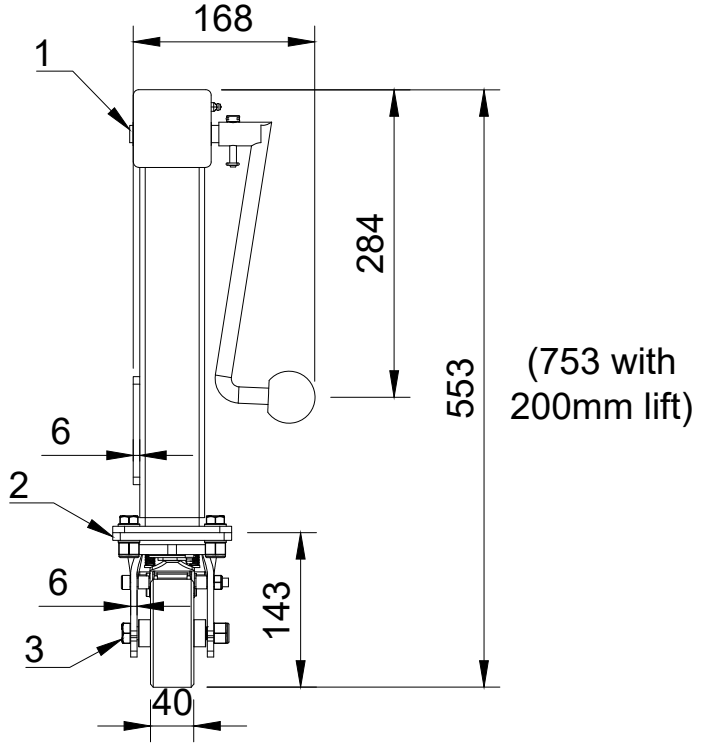

ITEM NO.	PART NUMBER	QTY
1	JZXHRH	1
2	BZMJ100PTBJSWB	1
3	FITTINGS	
	WM10X21X2	8
	BOLTM10X30	4
	NYLOCM12Z14MM	4



UNLESS OTHERWISE SPECIFIED DIMENSIONS ARE IN MILLIMETRES Unspecified Tolerances Machining ± 0.25mm Fabrication ± 1mm	DRAWING DISCLAIMER COPYRIGHT OF THIS DRAWING IS RESERVED BY BIL GROUP LTD. IT IS NOT REPRODUCED, COPIED, OR DISCLOSED TO A THIRD PARTY EITHER WHOLLY OR IN PART WITHOUT THE CONSENT IN WRITING OF BIL GROUP LTD	NAME	DATE	 BIL Group Ltd Porte Marsh Road Calne, Wiltshire, SN11 9BW United Kingdom Tel +44 (0)1249 822 222 www.bilgroup.co.uk	REV 1	
		DRAWN BY	Matt			17/11/23
		APPROVED BY	Kevin			17/11/23
		SCALE	1:7			
		WEIGHT	10.542kg			
DWG NO. JAZHS100PTBJSWBRH			SHEET 1 OF 1			