

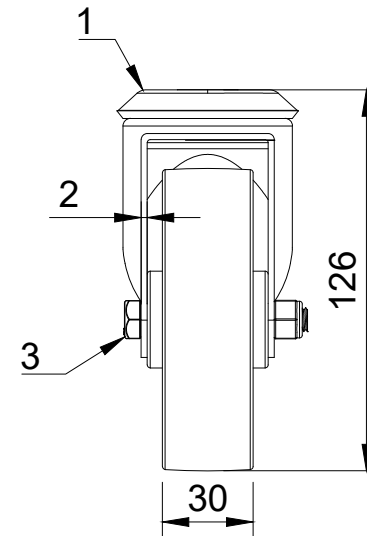

ITEM NO.	PART NUMBER	QTY
1	BZBC100ASBH12	1
2	BZMM100WNPRB	1
3	AXLE KIT	
	TUBEM12X40	1
	HEXBOLTM8X55Z8.8	1
	NYLOCM8Z	1



UNLESS OTHERWISE SPECIFIED DIMENSIONS ARE IN MILLIMETRES  Unspecified Tolerances Machining ± 0.25mm Fabrication ± 1mm	DRAWING DISCLAIMER  COPYRIGHT OF THIS DRAWING IS RESERVED BY BIL GROUP LTD. IT IS NOT REPRODUCED, COPIED, OR DISCLOSED TO A THIRD PARTY EITHER WHOLLY OR IN PART WITHOUT THE CONSENT IN WRITING OF BIL GROUP LTD	NAME	DATE		BIL Group Ltd Porte Marsh Road Calne, Wiltshire, SN11 9BW United Kingdom Tel +44 (0)1249 822 222 www.bilgroup.co.uk		
		DRAWN BY	Matt			18/10/23	
		APPROVED BY	Kevin	18/10/23	DWG NO.	BZBC100NPBBH12	REV 1
		SCALE	2:5		BZBC100NPBBH12 SHEET 1 OF 1		
		WEIGHT	0.548kg				