

ITEM NO.	PART NUMBER	QTY
1	BZSPH150AS	1
2	BZXH150WPNBJM20	1
3	AXLE KIT	
	TH20X5X12	2
	HEXBOLTM12X90Z8.8	1
	NYLOCM12Z14MM	1
4	FPSWBAPLP	1

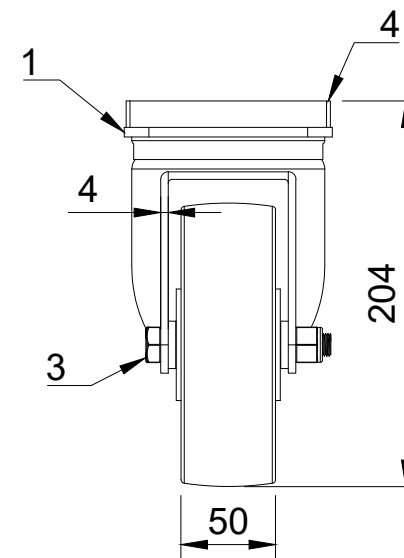

UNLESS OTHERWISE SPECIFIED DIMENSIONS ARE IN MILLIMETRES

Unspecified Tolerances  
Machining ± 0.25mm  
Fabrication ± 1mm

DRAWING DISCLAIMER

COPYRIGHT OF THIS DRAWING IS RESERVED BY BIL GROUP LTD. IT IS NOT REPRODUCED, COPIED, OR DISCLOSED TO A THIRD PARTY EITHER WHOLLY OR IN PART WITHOUT THE CONSENT IN WRITING OF BIL GROUP LTD

	NAME	DATE
DRAWN BY	Matt	15/11/23
APPROVED BY	Kevin	15/11/23
SCALE	1:4	
WEIGHT	2.635kg	

 BIL Group Ltd  
 Porte Marsh Road  
 Calne, Wiltshire, SN11 9BW  
 United Kingdom  
 Tel +44 (0)1249 822 222  
 www.bilgroup.co.uk

DWG NO. **BZSPH150XPNBJFP** REV **1**  
**BZSPH150XPNBJFP** SHEET 1 OF 1