

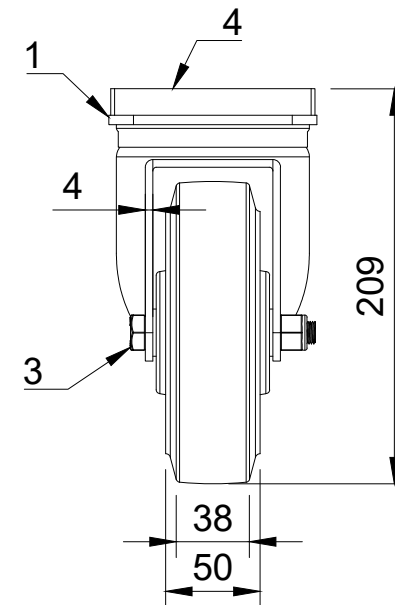

ITEM NO.	PART NUMBER	QTY
1	BZSPH150AS	1
2	BZH160WSRNBJM20	1
3	AXLE KIT	
	TH20X2X12	2
	HEXBOLTM12X90Z8.8	1
	NYLOCM12Z14MM	1
4	FPSWBAPLP	1



UNLESS OTHERWISE SPECIFIED DIMENSIONS ARE IN MILLIMETRES Unspecified Tolerances Machining ± 0.25mm Fabrication ± 1mm	DRAWING DISCLAIMER COPYRIGHT OF THIS DRAWING IS RESERVED BY BIL GROUP LTD. IT IS NOT REPRODUCED, COPIED, OR DISCLOSED TO A THIRD PARTY EITHER WHOLLY OR IN PART WITHOUT THE CONSENT IN WRITING OF BIL GROUP LTD	NAME Matt	DATE 09/11/23		BIL Group Ltd Porte Marsh Road Calne, Wiltshire, SN11 9BW United Kingdom Tel +44 (0)1249 822 222 www.bilgroup.co.uk		
		DRAWN BY Matt	DATE 09/11/23		DWG NO. BZSPH160SRNBJFP	REV 1	
		APPROVED BY Kevin	DATE 09/11/23	BZSPH160SRNBJFP		SHEET 1 OF 1	
		SCALE 1:4	WEIGHT 2.812kg				